

CPT Line 2 Door Refrigerated Counter (R290)

ITEM # _____

MODEL # _____

NAME # _____

SIS # _____

AIA # _____



111110 (ZK2H7AA)

2-door refrigerated counter, -2/+10°C, AISI 304 (R290) without work top

Short Form Specification

Item No. _____

AISI 304 stainless steel panels, AISI 430 bottom panel, galvanized back panel. N. 2 full doors. Built-in refrigeration unit. Operating temperature: -2/+10°C. R290 gas in refrigeration circuit. Supplied with 1 grid for each door compartment

Main Features

- Preservation performances and temperature uniformity within the cell guaranteed at 5-HEAVY DUTY (40°C) working conditions according to EN16825:2016 test protocol.
- Adjustable temperature range from -2 °C to +10 °C to suit meat, fish and dairy storage requirements.
- Large digital white-digit display with humidity selection button (3 preset level), internal temperature display and setting, manual activation of defrost cycle and turbo frost cycle (to rapidly cool warm loads).
- Equipped with forced air circulation system for rapid cooling and temperature distribution within the cell.
- 0mm clearance installation space: tower configuration cooling unit guarantee performance with frontal ventilation only; this unique solution allows installation against the wall or side by side with other appliances, even on the cooling unit side to maximize the use of kitchen space.
- Combination of doors and drawers to suit any configuration needed, with the possibility to change the configuration on site. Right cooling unit available on request.
- Frontal and easy access to all components in the cooling unit.
- Fully compliant HACCP digital control: when temperature exceeds critical limits, acoustic and visual alarms are activated. Up to two months of event are kept in memory.
- Anti-tilt runners accept GN 1/1 containers.
- Self closing stainless steel doors (< 90°).
- Certified safety CE requirements.
- Prearranged to fit RS485 port to facilitate connection to a remote computer and integrated HACCP systems.
- Hot gas automatic evaporation of defrost water.
- Mounted on stainless steel feet to give 150 mm (-5/+50 mm) clearance for ease of cleaning the floor.
- External bottom panel in stainless steel.
- External back panel in galvanized steel.
- Connectivity ready for real time access to connected appliances from remote and data monitoring (requires optional accessory).
- Easy serviceability thanks to the intuitive control panel with access via app.
- Integrated RS485 port to facilitate connection to a remote computer and integrated HACCP systems.

Construction

- 2 compartments with 2 doors.
- Interior base with rounded corners, pressed from a single sheet.
- Ease of cleaning and high hygiene standards thanks to the rounded internal corners, the easily removable runners, grids and air conveyors.
- Internal structure with 15 charging positions (3 cm pitch) available to host GN 1/1 grids, ensuring higher net capacity and a greater storage space.
- Internal and external doors, front, back and side panels in AISI 304 Stainless steel.
- Built-in refrigeration unit.
- Delivered with UK plug.
- Developed and produced in ISO 9001 and ISO 14001 certified factory.
- Fault code display.

APPROVAL: _____

- Extractable cooling unit to facilitate maintenance.

Included Accessories

- 2 of Kit 1/1 grey rilsan grid and 2 side runners for refrigerated counters PNC 881109

Optional Accessories

- 2x1/2 drawer kit for refrigerated counters PNC 881079
- 3x1/3 drawer kit for refrigerated counters PNC 881080
- 1/3 and 2/3 bottle drawer kit for refrigerated counters PNC 881081
- 1/1GN grey rilsan grid for refrigerated counters PNC 881107
- 2 side runners for 1/1 GN refrigerated counters PNC 881108
- Kit 1/1 grey rilsan grid and 2 side runners for refrigerated counters PNC 881109
- 1/1 GN plastic container, H=65 mm PNC 881110
- 1/1 GN plastic container, H=100 mm PNC 881111
- 1/1 GN plastic container, H=150 mm PNC 881112
- Worktop for refrigerated counter, 2 compartments PNC 881124
- Worktop with upstand for refrigerated counter, 2 compartments PNC 881127
- Kit 4 wheels, H=100 mm (2 with brakes) for refrigerated counters PNC 881191
- Kit 4 wheels, H=150 mm (2 with brakes) for 2&3 compartment refrigerated counters PNC 881193
- Lock for refrigerator/freezer counters with 2 compartments - h700mm PNC 881242

Front

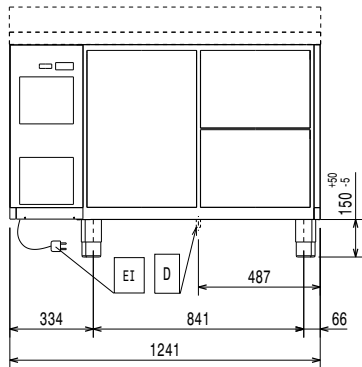

Side

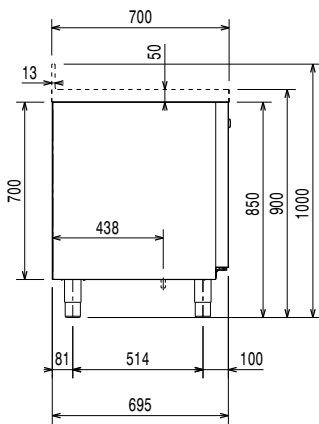

EI = Electrical inlet (power)

Top

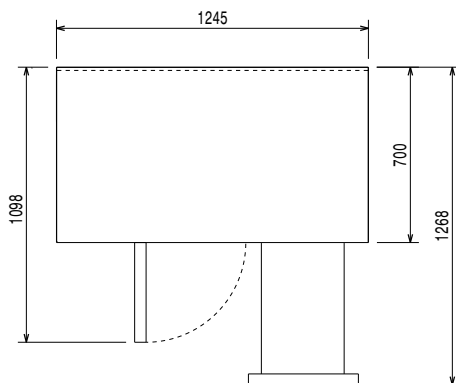

Electric

Supply voltage:	220-240 V/1 ph/50 Hz
111110 (ZK2H7AA)	
Electrical power max.:	0.22 kW
Defrost Power:	0.2 kW
Plug type:	CE-SCHUKO

Key Information:

Gross capacity:	290 lt
Net Volume:	180.8 lt
External dimensions, Width:	1241 mm
External dimensions, Depth:	700 mm
External dimensions, Height:	850 mm
Internal Dimensions, Width:	798 mm
Internal Dimensions, Depth:	560 mm
Internal Dimensions, Height:	550 mm
Net weight:	90 kg
Shipping volume:	1.08 m ³
Depth with doors open:	1110 mm
Height adjustment:	-5/50 mm

Refrigeration Data

Control type:	Digital
Compressor power:	0.25 hp
Refrigeration power at evaporation temperature:	-10 °C
Min/Max internal humidity:	40/85
Operating temperature min.:	-2 °C
Operating temperature max.:	10 °C
Operating mode:	Ventilated

Sustainability

Current consumption:	1.6 Amps
Energy Class (EU Reg. 2015/1094):	A
Yearly and daily energy consumption (EU Reg. 2015/1094):	482kWh/year - 1kWh/24h
Climate class (EU Reg. 2015/1094):	Heavy Duty (5)
Energy Efficiency Index-EEI (EU Reg. 2015/1094):	21,40
Refrigerant type:	R290
GWP Index:	3
Refrigeration power:	358 W
Refrigerant weight:	50 g

EU energy labelling from 1st July 2016

The European energy labelling scheme for professional refrigerators and freezers is based on requirements setting Minimum Energy Performance standards for commercial refrigeration cabinets sold within the EU. These requirements are designed to drive energy efficiency and environmentally friendly approach for professionals. The European energy labelling scheme will apply to all manufacturers and importers who sell and market products within the EU and it is mandatory across Europe. Important: all products which consume energy above the minimum level will not be able to be sold within the EU from 1 July 2016.

SI 2020 No. 1528.

Important: all products which consume energy above the minimum level will not be able to be sold within the EU from 1 July 2016.

